

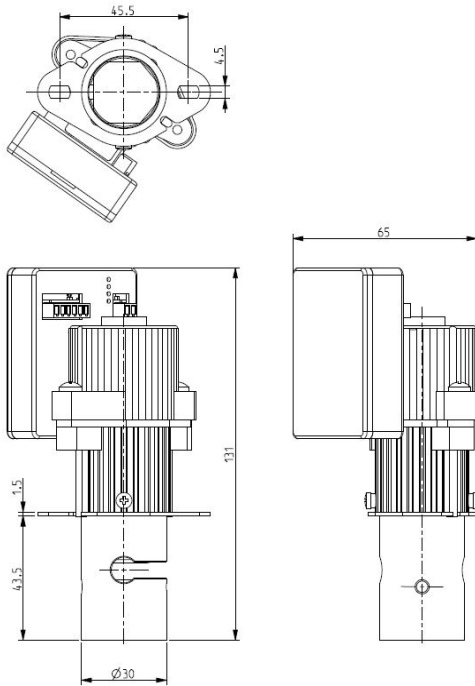

STEPPER MOTOR PINCH VALVE 2-WAY CONTROLLED VIA ANALOG INPUT

S170XA01X2900VU
S170XA01X3900VU



► GENERAL FEATURES

Stepper motor pinch valve, suitable to shut off media without producing neither turbulent flows, nor dead spaces. Particularly suitable for most of the analytical, medical and food applications. The "OPEN" and "CLOSE" positions of the valve will be set as indicated in the section "OPERATING INSTRUCTIONS". The system allows a bi-directional through flow and a high flow rate. The valve is suitable for elastic tubings with hardness up to 90 Shore A. **The tubing (not included in our supply) is the only material in contact with the fluid.**

► MATERIALS

<i>Body</i>	Anodized aluminium
<i>Pinching device</i>	POM (reinforced acetal copolymer)
<i>Engine cover</i>	PA (Polyamide)
<i>Board cover</i>	PA (Polyamide)

► ELECTRIC FEATURES

<i>Power supply</i>	[12÷24] V
<i>Continuous duty</i>	ED 100%
<i>Minimum step</i>	0.033mm/step
<i>Insulation class</i>	B (130°C)
<i>Ambient temperature</i>	-10°C +60°C
<i>Electric connection</i>	Molex pitch 2.54mm 6 pins Molex pitch 2.54mm 2 pins
<i>Protection degree</i>	IP 40 (EN60529)

► LED INDICATIONS

<i>Red</i>	Alarm / Malfunction
<i>Yellow</i>	See Operation below
<i>Green</i>	See Operation below
<i>Blue</i>	Programming mode

TUBINGS MAX O.D. (mm)	Pinching strength (N)	Opening/closing speed (mm/s)	Analog Input	Series and type	Power absorption (W)	Notes	Weight (kg)
				Valve	In operation		
9,5	up to 80	3,33	0-5V	S170XA01X2900VU	9	-	0.25
			4-20mA	S170XA01X3900VU			

► NOTE

- Some data, e.g. actuating time and power absorption, are directly depending on the electronic control and can vary accordingly
- Valve position fixed on loss of power. "Fail Saving" function available on demand.

THE VALIDITY OF REPORTED DATA IS REFERRED TO THE DATE OF ISSUE. POSSIBLE UPDATES ARE AVAILABLE ON REQUEST

S170XA01X2900VU - S170XA01X3900VU

► CONNECTION

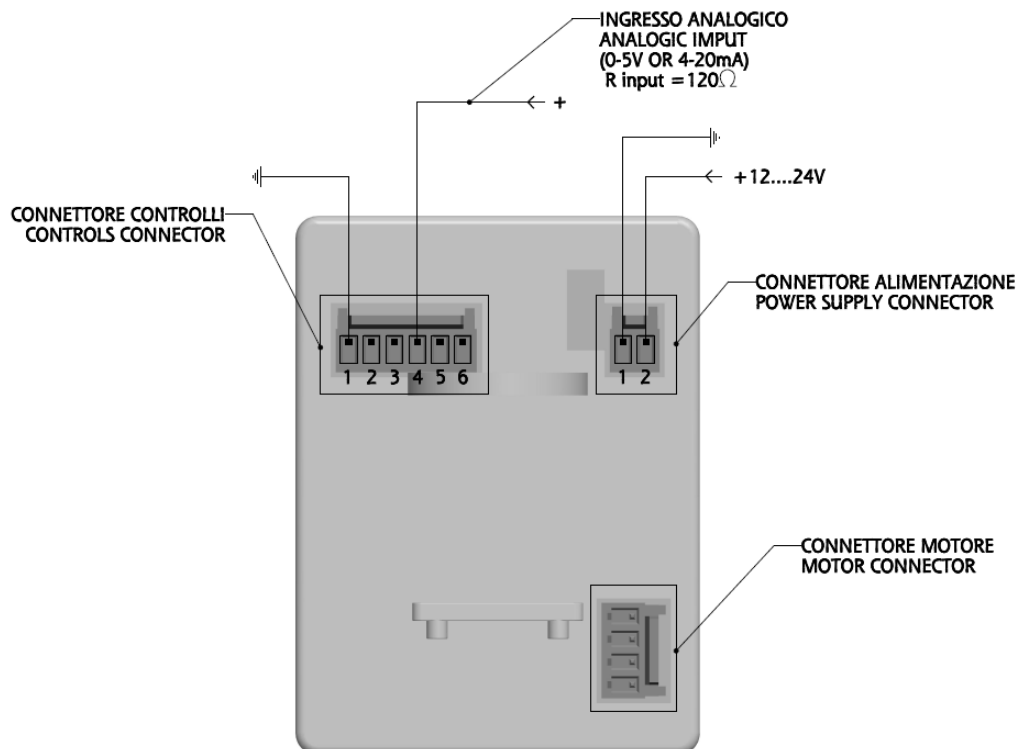

► OPERATION

When power is supplied, the valve will reset (red and green LEDs on) and will automatically move to CLOSED position. Depending on the version, there will be:

- green LED on and yellow LED flashing for the "voltage version" [0 ÷ 5]V
- yellow LED on and green LED flashing for the "current version" [4 ÷ 20]mA.

- Depending on the chosen version, supply 5V or 20mA input to have a complete opening of the valve.
- Insert the tube in the respective slot

The valve is now operational and by providing a [4 ÷ 20]mA or a [0 ÷ 5]V signal (depending on the chosen version), the valve will act accordingly.

LED signals meaning:

- green LED on and yellow LED flashing → analogic input on ("voltage version")
- yellow LED on and green LED flashing → analogic input on ("current version")

Note:

Valve position fixed on loss of power. When the power will be restored, the valve will reset (red and green LEDs on) and will automatically move to the position set by the input analog signal.