



Moduflex Proportional Technology

Proportional Regulator MPT40

1/8" and 1/4" ported

Catalogue no. PDE2534TCUK-ab



Moduflex proportional technology

Man-machine interface

High visibility LED display
Easy to read characters
All controls on the same face

Total flexibility

User friendly and easily accessible software
One basic unit suits all customer requirements

Special applications

Food version:
Clean line design
Suitable for washdown

Compact & light weight

Small envelope
Light weight (P3HP = 285 gram)

Flexible mounting options

Stand-alone
Foot bracket mounting
DIN-rail mounting



Moduflex proportional technology

Generic Industries



The new MPT40 Regulator is designed to quickly and accurately adjust and maintain a set output pressure.

The unit will operate regardless of flow, in response to an electronic control signal. The medium can be compressed air or an inert gas.

Applications for this technology are virtually unlimited; from paint spray control, paper manufacture and printing to weaving and laser cutting control; in fact anywhere that requires accurate remote pressure control.

Automation

In the field of general automation, the need to control processes or movement via electronic signals is of paramount importance. This new unit provides the facility to incorporate pressure control into a fully integrated control system.



Packaging and Food



The Packaging and Food industry provides another ideal area for application of the Electronic Proportional Regulator, where fine control of tension on wrapping foils and paper is required. The degree of control and the ability to manually change parameters makes this unit ideally suited to the varying requirements of this industry.

Automotive

Applications for this innovative product in the Automotive industry can be seen in major manufacturers 'body-in-white' lines.

The control of clamping and welding forces during panel assembly is an ideal application, also accurate control in paint dipping and spraying can be achieved



Outstanding performance

- Very fast response times
- Full flow exhaust
- Excellent linearity

Moduflex proportional technology

Why proportional technology ?

The difference between open or closed circuit control

Standard pressure regulators, designed as part of our FRL series go a long way towards meeting our customers needs. In most cases these regulators work well in general pneumatic and automation applications. However, sometimes the application calls for more precise pressure control. The effects of time, cycling, input, back pressure or pressure and flow variation can all cause inconsistencies in pneumatic systems. Our new Proportional Regulators are designed to eliminate those inconsistencies.

Open Control Circuit

In a normal pressure regulated control system, the inlet pressure (p1) is converted into the output pressure (p2) by the regulator. The set pressure (set value) is usually manually set by adjusting the control knob and in normal circumstances the regulator maintains the output pressure (actual value).

No facility for monitoring the output pressure is provided and there is consequently no way of checking that the set value and the actual value are the same. Also, no account is taken of external influences such as air consumption by the system, which can drastically alter the actual value.

Closed Loop Control Circuit

The input signal (set value) is converted into the output value (actual value) - as in control systems but this output value is continuously measured and compared with the input signal. If they are different, the regulation unit intervenes and adjusts the output value to correspond to the set value.

Proportional Pressure Regulators

The new P3H-P provides all the advantages of a closed circuit regulated system. When a set value is defined via the input signal (e.g. 0-10V), the pressure regulator sets the corresponding output pressure (e.g. 0-10 bar). At the same time the integrated pressure sensor measures the actual pressure at the unit's outlet (actual value).

If the electronic regulation system finds that the actual value has deviated from the set value, it immediately corrects the actual value. This is a continuous process ensuring fast, accurate pressure regulation.

Typical application in automotive body in white welding pressure control

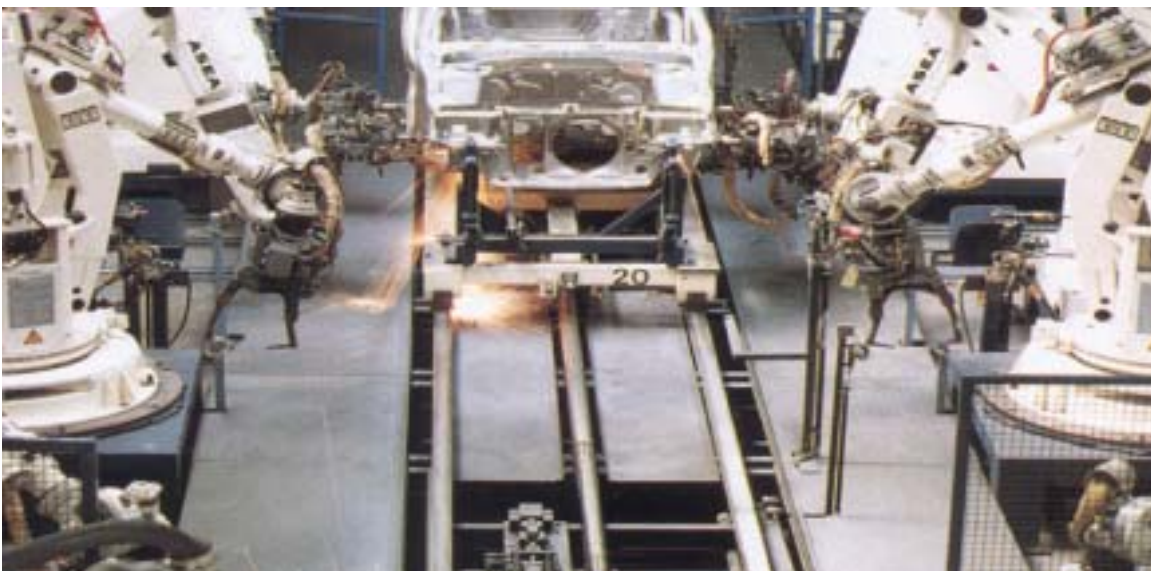

Order Key

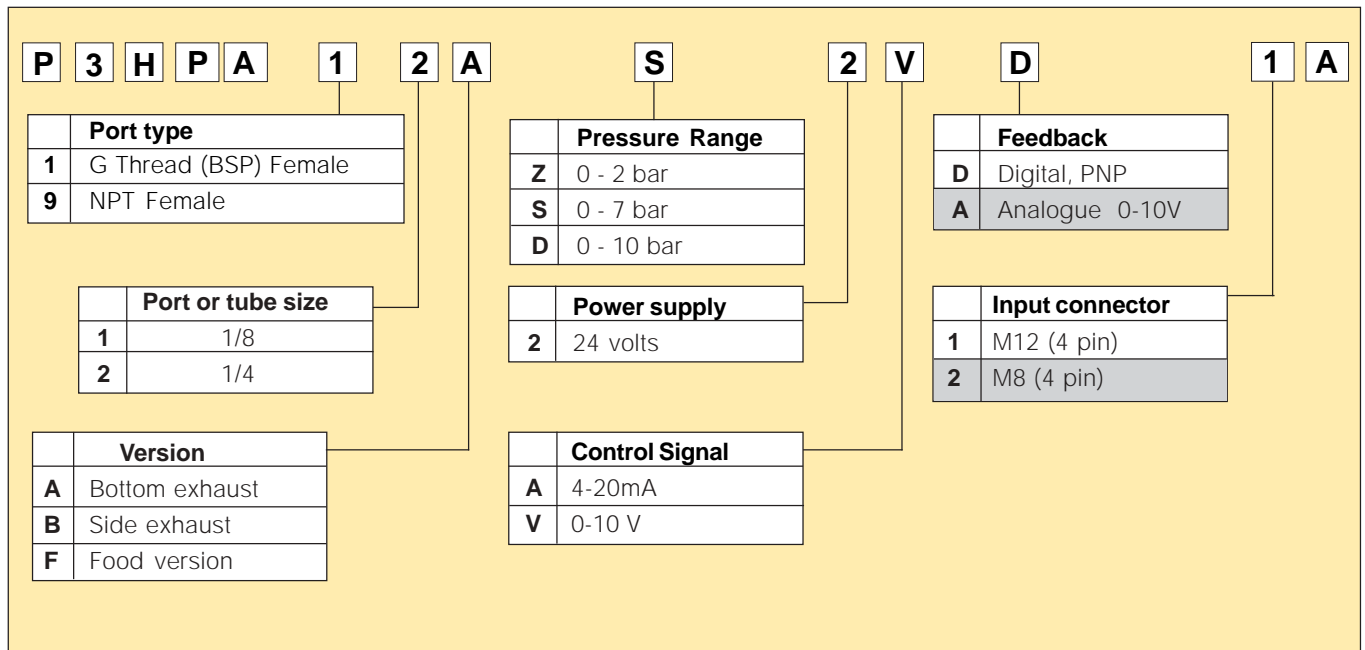

On request

Popular Options

Port Size	Order Code	Control Signal	Output Pressure
G1/4	P3HPA12AZ2AD1A	4-20mA	0 - 2 bar
G1/4	P3HPA12AS2AD1A	4-20mA	0 - 7 bar
G1/4	P3HPA12AD2AD1A	4-20mA	0 - 10 bar
G1/4	P3HPA12AZ2VD1A	0 - 10 V	0 - 2 bar
G1/4	P3HPA12AS2VD1A	0 - 10 V	0 - 7 bar
G1/4	P3HPA12AD2VD1A	0 - 10 V	0 - 10 bar

Mounting Options

Order Code	Description
P3HKA00MK	DIN rail mounting kit
P3HKA00MF	Foot bracket mounting kit

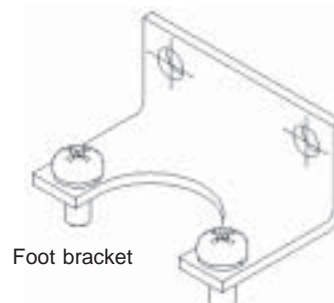

Moduflex proportional technology

Technical information

Pneumatics

Working medium

Compressed air or inert gasses, filtered to min. 40 μ , lubricated or non-lubricated, dried or un-dried, pressure dewpoint 3-5 $^{\circ}$ C.

Supply pressure

Primary (input pressure):
 10,5 bar: 0 - 10 bar output range
 7,5 bar: 0 - 7 bar output range
 2,5 bar: 0 - 2 bar output range
 (others on request)

Pressure control range

Available in three pressure ranges, 0-2 bar, 0-7 bar or 0-10 bar. Other ranges on request. Pressure range can be changed through the software at all times. (parameter 19)

Burst pressure of sensor

2 x F.S.*

Air consumption

No consumption in stable regulated situation.

Display

The regulator is provided with a digital display, indicating the output pressure, either in BAR or PSI.
 The factory setting is as indicated on the label, can be changed through to software at all times (parameter 14).

Electronics

Supply voltage

24 VDC +/- 10%

Power consumption

Max. 1.1W with unloaded signal outputs

Control signals

The electronic pressure regulator can be externally controlled through an analogue control signal of either 0-10V or 4-20mA.

Output signals

As soon as the output pressure is within the signal band a signal is given of 24V DC, PNP Ri = 1 kOhm
 Outside the signal band this connection is 0V.

Connections

Central M12 connector 4-pole

The electrical connections are as follows:

Pin no.	Function	Colour
1	24V supply	brown
2	0-10V control signal Ri = 100 kOhm	white
3	0V (GND) supply	blue
4	24V alarm output signal	black

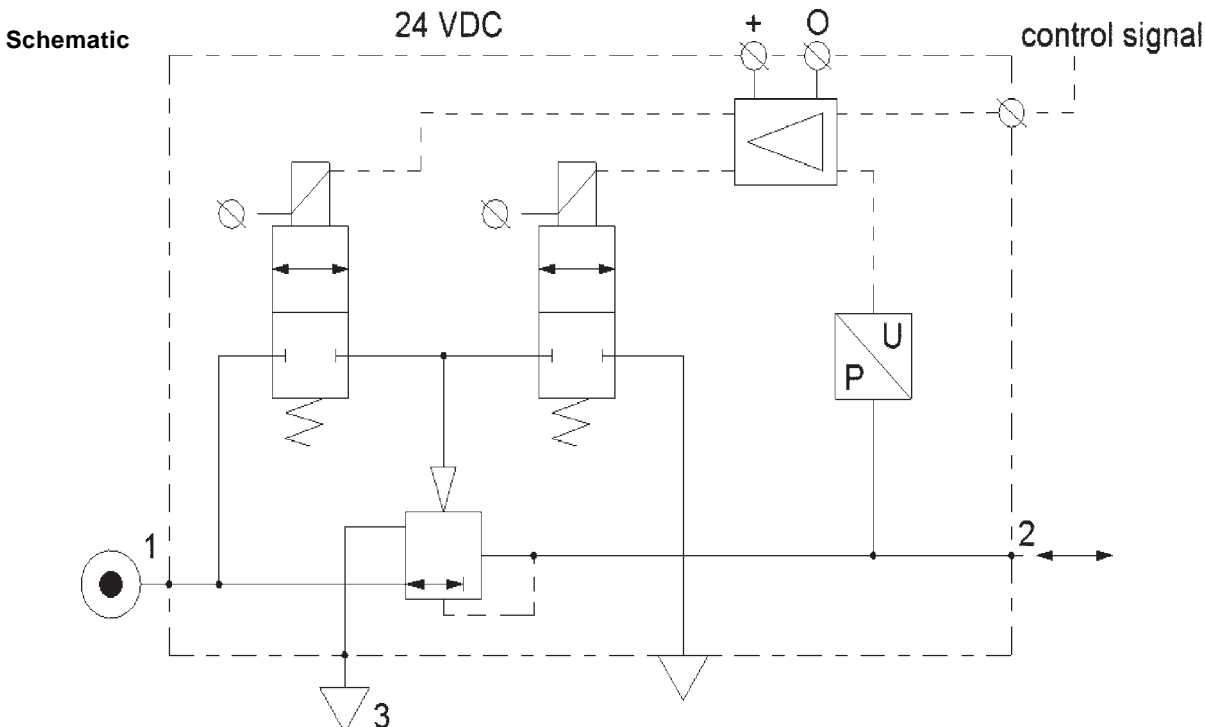

*F.S. = Full scale = chosen max. output pressure = 100% pressure control range.

Technical information

Dead band

The dead band is preset at 1,1% F.S.*

Accuracy

Hysteresis is equal to the dead band setting (1,1% F.S.*)
Linearity: = < 0,3% F.S.*

Signal band

The signal band is preset at 5% F.S.*

Proportional band

The proportional band is preset at 10% F.S.*

Fail safe operation

After interrupting the power supply the present output pressure is maintained at approximately the same level.
After switching on the power supply again the pressure can be adjusted immediately by giving a new control signal.

Full exhaust

Complete exhaust of the regulator is obtained at 1% of F.S.*

Temperature range

0°C up to +50°C

Degree of protection

IP 65

EU conformity

CE: standard

EMC: according to directive 89/336/EEC

The new pressure regulator is in accordance with:

EN 61000-6-1:2001

EN 61000-6-2:2001

EN 61000-6-3:2001

EN 61000-6-4:2001

These standards ensure that this unit meets the highest level of EMC protection.

Mounting position

Preferably vertically, with the cable gland on top.

Air consumption

Under normal conditions and in steady state there is no air consumption.

Materials

Parts in contact with the working medium:

- magnet core: steel
- solenoid valve poppet: FPM
- core housing: brass
- solenoid valve housing: Techno polymer
- regulator housing: Techno polymer
- valve: Polyurethane
- seats and auxiliary piston: Delrin, Brass
- remaining seals: NBR
- port connections
standard version : brass
food : stainless steel

Regulation characteristics

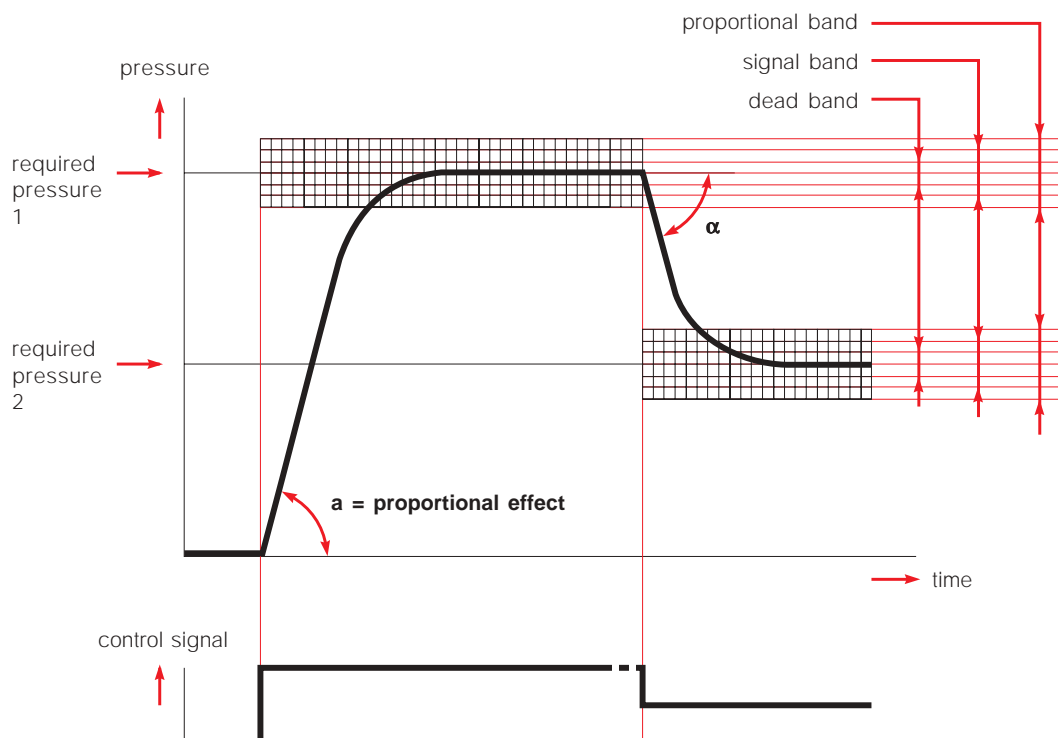

*F.S. = Full scale = chosen max. output pressure = 100% pressure control range.

Moduflex proportional technology

Advanced functionality

Pilot valve protection

When the required output pressure can not be achieved because of a lack of input pressure the unit will open fully and will display NoP. Approximately every 10 seconds the unit will retry. The output pressure will then be approximately equal to the inlet pressure. As soon as the input pressure is back on the required level, the normal control function follows.

Safety exhaust

Should the control signal fall below 0,1 volts the valve will automatically dump downstream system pressure .

Fail safe

When the supply voltage drops below 19VDC, the electronic control reverts to the fail safe mode. The last known output pressure is maintained at approximately the same level depending upon air consumption. The digital display indicates the last known pressure setting. When the supply voltage is reinstated to the correct level, the valve moves from the fail safe mode and the output pressure immediately follows the control signal requirement. The display indicates the actual output pressure.

Input protection

The unit has built-in protection against failure and burnout resulting from incorrect input value, typically:

The 24v DC supply is incorrectly connected to the setpoint input, the display will show 'OL', as an overload indication. The unit will need to be rewired and when correctly connected will operate normally.

The overload indicator 'OL' will also appear should the wrong input value be applied or the wrong input value be programmed: (0 - 10v instead of 4 - 20mA or conversely 4 - 20mA rather than 0 - 10v). To correct this a different set point value should be input or the unit reprogrammed to correct the set point value acceptance. (via parameter 4).

Response times

To fill volume of 100cm³, connected to the outlet of the regulator:

- Pressure increase from 2 to 4 bar » 30 msecs
- Pressure increase from 1 to 6 bar » 120 msecs
- Pressure decrease from 4 to 2 bar » 60 msecs
- Pressure decrease from 6 to 1 bar » 160 msecs

Settings

The regulator is pre-set at the factory. If required, adjustments can be made.

Flow characteristics

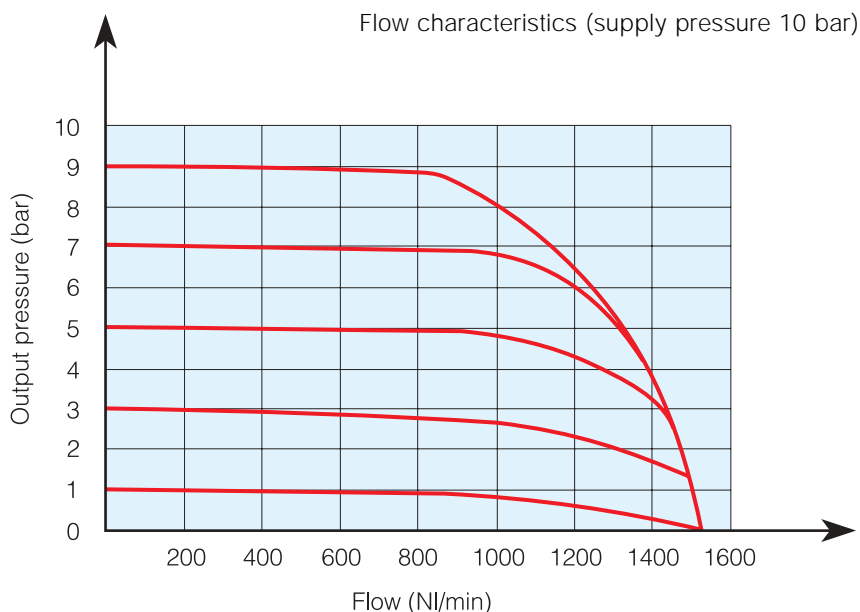

How to change parameters

Pressing the Accept key "acc" for more than 3 seconds, will activate parameter change mode. The user can then select the parameters by pressing up or down key. (display will show Pxx). When parameter number is correct, pressing accept again will enter parameter number.(display will show parameter value).

Pressing the up or down key will change the parameter itself. (display will flash indicating parameter editing mode). Pressing the accept key will accept the new parameter value. (all digits will flash whilst being accepted).

After releasing all keys, the next parameter number will be presented on the display. (you may step to the next parameter). When no key is pressed, after 3 seconds the display will show the actual output pressure.

Manual mode

When keys DOWN and UP are pressed during startup, (connecting to the 24V power supply) manual mode is activated. This means that the user is able to in/decrease the output pressure of the P3H, by pressing the UP or DOWN key. During this action the display will blink, indicating that the manual mode is activated.

Back to factory setting

After start up. (Power is on)

Parameter 0 = 3 (green_key function) Re-set to factory setting

Entering this value in parameter 0 will store the calibrated factory data into the working parameters. (Default calibration data is used)

Behaviour control

The regulation speed of the pressure regulator can be modified by means of one parameter. (P 20)

The value in this parameter has a range from 0-5, a higher value means slower regulation speed but it will be more accurate. When the value 0 is entered, you are able to create your own custom settings through parameters 12, 13 and 21.

Preset pressure

If there is a need to keep secondary side pressurized at all times. The pre-set pressure can be set through parameter 18. (Note: value is set in mbar.)

Changeable user parameters*	Setting	Standard value	Description	Unit	Action	Result
0	3		green key		Back to factory settings	Back to normal settings
4	0 1	1	mA V		Set setpoint input to mA Set setpoint input to volt	0(4)-20mA, (P29) 0-10V
6	0 1	0	Alarm output Analog output		Set output to digital alarm output Set output to analogue output	24V= in band 0-10V-P_out
9	-	+			adjust display value	
12	50 to 250	100		x 10 mbar	Set proporitional band	0,5 to 2,5 bar
13	2 to 40	15		x 10mbar	Set deadband area	20 to 400 mbar
14	0 1		bar psi		set pressure indicating	value displayed in bar value displayed in psi
18	0 to 200	0		x 10 mbar	Set preset pressure (x10 mBar)	0 to 2 bar
19	0 to 100	100		% F.S.	Pressure correction	0 to P-max
20	0 1 2 3 4 5	3	Custom set Fastest Fast Normal Slow Slowest		Set behaviour control	P 12,13, 21
21	5 to 100	10			Set proportional effect	fastest regulation slowest regulation
39	-	-			Software version	three digit software version

*Other parameter settings are available. Consult factory.

Moduflex proportional technology

Troubleshooting guide

Problem	Possible Reason	Solution
Display will not light up	No 24 volts power supply	Check if the wiring is connected according to the schematic wiring diagram
Unit will not, or not correctly respond to given setpoint	Wrong current applied (i.e. Volt instead of mA or mA instead of Volt	Change setpoint current or re configure the setpoint current through the software by changing parameter 4 Check wiring if the setpoint signal lead is connected to the right pin within the male M12 connector (should be pin 2)
	Setpoint signal is not stable enough	Stabilize setpoint signal input
Display shows NoP.	Unit detects that required output pressure is higher than the supplied pressure	Adjust the inlet pressure to a higher value, preferably 0,5 bar higher than requested output pressure Give lower setpoint value which corresponds to a output pressure lower than the inlet pressure
	No inlet pressure at all	Connect port 1 to the supply pressure
Unit behaviour is not considered normal	Faulty settings made in the parameters	Reset the unit to factory settings by using the green key function under parameter 0
Desired pressure can not be reached	Setpoint value to low	Increase setpoint value
	Pre-set pressure limit has been changed to a lower max. outlet pressure	Change max. outlet pressure back to required pressure by changing parameter 19
	Supply pressure is to low	Increase supply pressure
Secondary side stays pressurized	Setpoint value is higher than 0,1 Volt	Lower your setpoint value, preferably to 0 Volts
	Pre-set pressure has been enabled to a certain pressure	Reset parameter 18 to 0
Display shows unrealistic value	Display maybe configured in the wrong value (bar instead of psi)	Check through parameter 14, if the display value is set on either psi or bar, if necessary change it to the required setting
Unit response time too slow or too quick	Volume behind the unit is either too big or too small	Adjust the regulating speed of the unit through parameter 20
Unit gives too much overshoot	Relation between volume and response time is out of balance	Adjust response time to a higher value through parameter 20, to acheive more accurate behaviour
Unit is adjusting/regulating constantly	Airleakage in the system behind the unit	Resolve leakage
	Constant changing volume behind the unit	Unit needs to regulate to keep required pressure at the same level Try to minimize the volume changes
	"Deadband "area is set too small	Enlarge deadband setting through parameter 13 in the software (parameter 20 has to be set to 0 before changing parameter 13)
Can not enter software through touchpad	Unit is currently working/processing	Make sure that the unit is in steady state while activating the software
	Activating time is too short	Hold the accept button for at least 3 seconds
Display indicates 'OL'	Wiring not according to diagram (24 volt connected on the setpoint connection pin)	Rewire so that on the setpoint connection pin will be either 0-10v or 4-20mA
	Wrong setpoint value given in relation to programmed setpoint value acceptance	Change over setpoint value to either V or mA or Reprogramme the unit to the correct setpoint value via parameter 4
Any other problem		Please consult factory

SALE CONDITIONS

The items described in this document are available for sale by Parker Hannifin Corporation, its subsidiaries or its authorized distributors. Any sale contract entered into by Parker will be governed by the provisions stated in Parker's standard terms and conditions of sale (copy available upon request).

Dimensional drawings

Bottom exhaust version

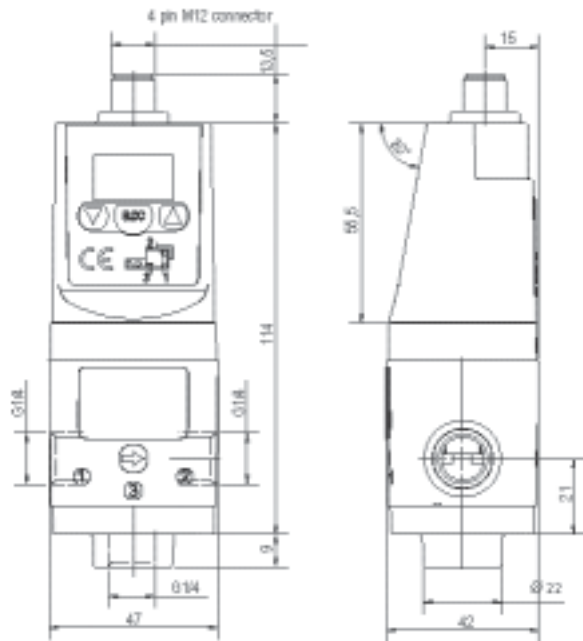

Side exhaust version

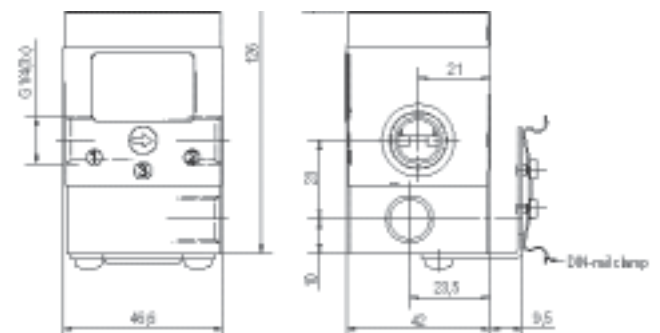
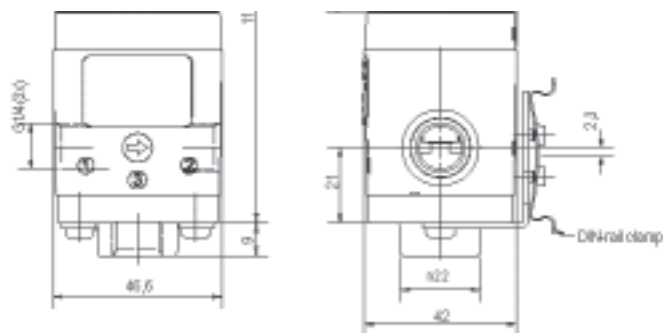
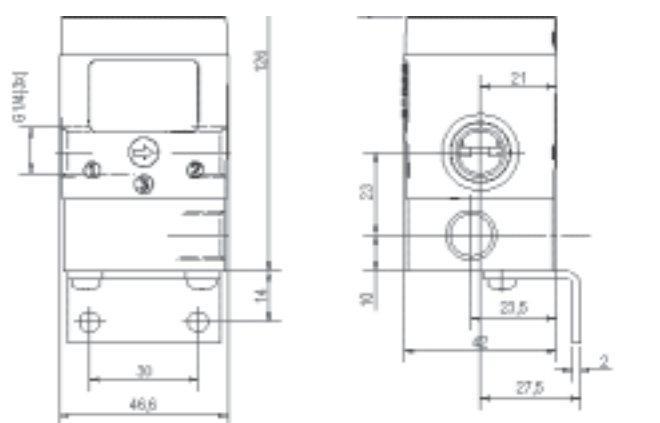
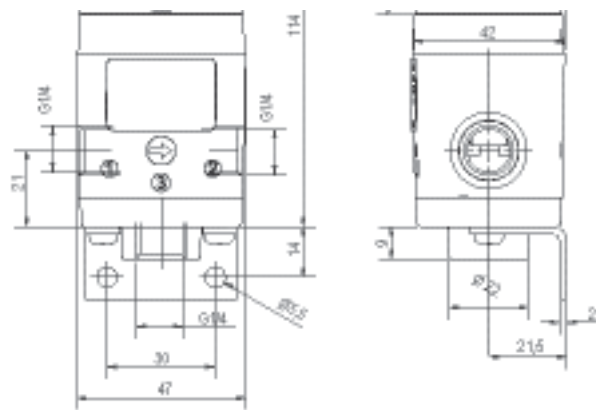
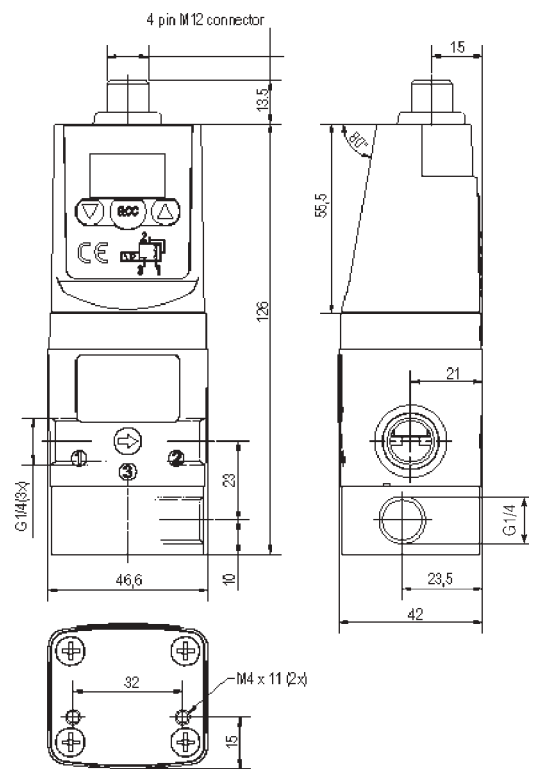

WARNING

FAILURE OR IMPROPER SELECTION OR IMPROPER USE OF THE PRODUCTS AND/OR SYSTEMS DESCRIBED HEREIN OR RELATED ITEMS CAN CAUSE DEATH, PERSONAL INJURY AND PROPERTY DAMAGE.

This document and other information from Parker Hannifin Corporation, its subsidiaries and authorized distributors provide product and/or system options for further investigation by users having technical expertise. It is important that you analyze all aspects of your application and review the information concerning the product or system in the current product catalog. Due to the variety of operating conditions and applications for these products or systems, the user, through its own analysis and testing, is solely responsible for making the final selection of the products and systems and assuring that all performance, safety and warning requirements of the application are met. The products described herein, including without limitation, product features, specifications, designs, availability and pricing, are subject to change by Parker Hannifin Corporation and its subsidiaries at any time without notice.

Pneumatic Division Sales Offices

Austria - Wr.Neustadt

Tel: +43 2622 23501
Fax: +43 2622 66212

Belgium - Nivelles

Tel: +32 67 280 900
Fax: +32 67 280 999

**Czech & Slovak
Republics - Prague**

Tel: +420 283 085 221
Fax: +420 283 085 360

Denmark - Ballerup

Tel: +45 43 560400
Fax: +45 43 733107

Finland - Vantaa

Tel: +358 9 4767 31
Fax: +358 9 4767 3200

France - Evreux

Tel: +33 820 825 239
Fax: +33 820 029 870

Germany - Kaarst

Tel: +49 2131 4016-0
Fax: +49 2131 4016 9199

Greece - Athens

Tel: +30 10 933 6450
Fax: +30 10 933 6451

Hungary - Budapest

Tel: +36 1 220 4155
Fax: +36 1 422 1525

Italy - Corsico, Milan

Tel: +39 02 4519 21
Fax: +39 02 4479 340

Netherlands - Oldenzaal

Tel: +31 541 585000
Fax: +31 541 585459

Norway - Langhus

Tel: +47 6491 1000
Fax: +47 6491 1090

Poland - Warsaw

Tel: +48 22 863 49 42
Fax: +48 22 863 49 44

**Portugal - Leça da
Palmeira**

Tel: +351 22 999 7360
Fax: +351 22 996 1527

Romania - Bucharest

Tel: +40 21 252 3382
Fax: +40 21 252 3381

Russia - Moscow

Tel: +7 095 234 0054
Fax: +7 095 234 0528

Slovenia - Novo mesto

Tel: +386 7337 6650
Fax: +386 7337 6651

Spain - Madrid

Tel: +34 91 675 7300
Fax: +34 91 675 7711

Sweden - Spånga

Tel: +46 (0) 8 5979 5000
Fax: +46 (0) 8 5979 5110

Switzerland - Biel

Tel: +41 32 3653711
Fax: +41 32 3653730

UK - Cannock

Tel: +44 1543 456000
Fax: +44 1543 456001

Ukraine - Kiev

Tel: + 380 44 220 7432
Fax: + 380 44 220 6534

**Parker Hannifin plc**

Pneumatic Division
Walkmill Lane, Bridgtown,
Cannock, Staffs. WS11 3LR
United Kingdom
www.parker.com/euro_pneumatic