

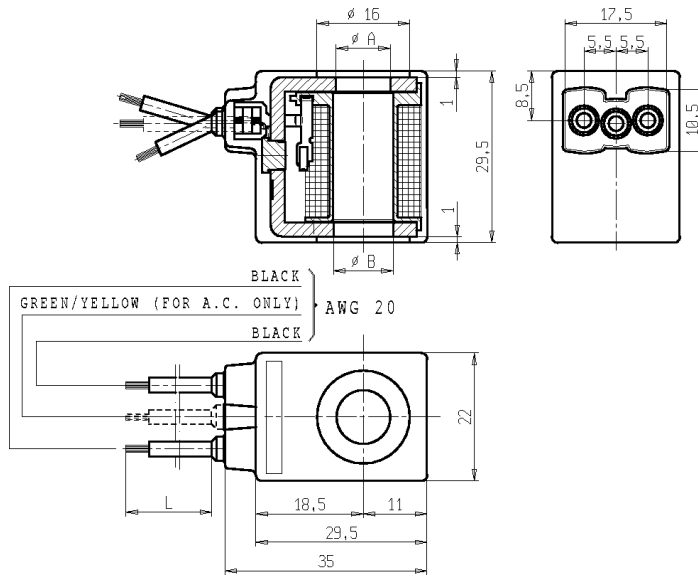

COIL – FLYING LEADS Series Z8..

Z8..

ISO 9001



NON STANDARD

FEATURES - Rated for continuous duty (ED 100%) in alternate current (AC) or direct current (DC). Vacuum impregnated winding by polyester resin, insulation class and encapsulation material as per table.

AMBIENT TEMPERATURE - -10°C +60°C

PROTECTION DEGREE - IP66, according to EN 60529 standard.

ELECTRIC CONNECTIONS - N° 3 wires AWG 20 (2 line + earth) length as per table for AC model
N° 2 wires AWG 20 (2 line) length as per table for DC model.

STANDARD VOLTAGES - Alternate current (AC) 24-110 (120/60Hz) -220 (240/60Hz) -230V/50Hz.
Direct current (DC) 12-24V.

TOLERANCE +10% -15% AC and +10% -5% DC.

TYPE	MAIN FEATURES	MODEL	POWER ABSORPTION			Cable free length L	HOLES		WEIGHT (kg)
			AC (VA)		DC (W)		Ø A	Ø B	
			Inrush	Holding					
Z835	- Class "F" (+155°C) - Wires in class "H" (+180°C) - PBT encapsulation (blue color)	A	10	7	6	260	9,3	10,3	0,065
		Y				1000			0,095
Z815		A				260	10,3	10,3	0,065

NOTES - Other voltages on request.
- PBT = glass fibre reinforced Polybutylene-Terephthalate

NB – THE VALIDITY OF REPORTED DATA IS REFERRED TO THE DATE OF ISSUE. POSSIBLE UPDATING ARE AVAILABLE ON REQUEST