

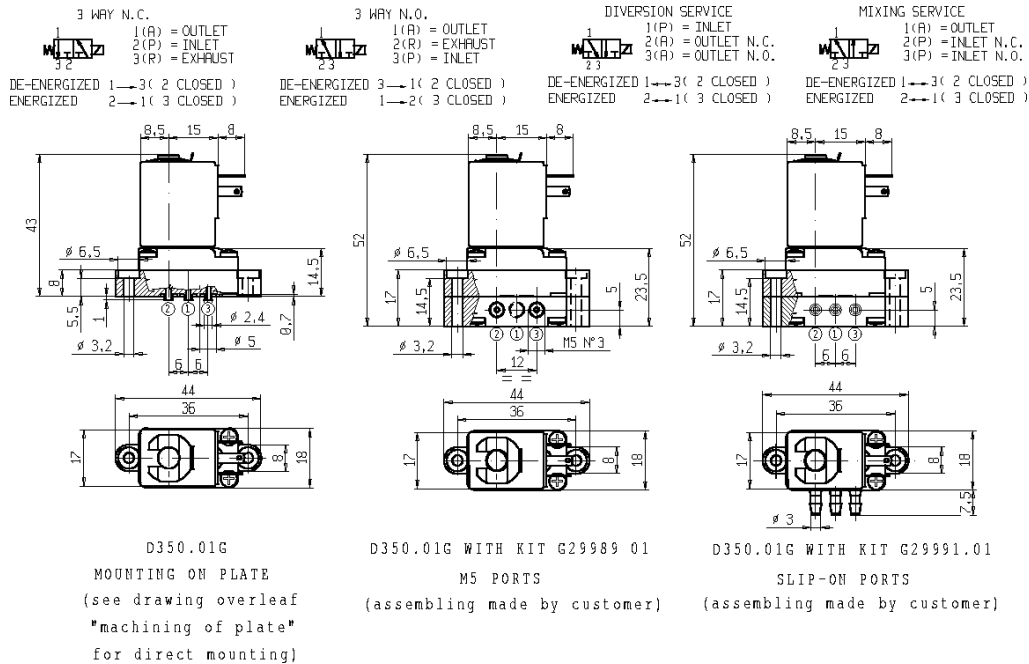

D350

3/2 – DRY - MICRO SOLENOID VALVE - Universal service (U.S.) Series D350 - Coil Z030A

ISO 9001



FEATURES - Direct operation, designed for manifold mounting. The customer can also add an adaptor with either M5 female threaded ports (G2998901) or slip-on ports (G2999101). Minimum overall dimensions. The actuator is totally separated from the medium so that the wetted parts are just the body and the diaphragm. Suitable to shut off liquid and gaseous media compatible with the construction materials. Possibility of disassembling for inspection. The parts subject to sliding friction are duly coated by PTFE (polytetrafluoroethylene) based self lubricating material. Valves delivered with sealing O-rings.

MOUNTING - In any position, vertical with coil upwards preferred.

VALVE - Moulded body in PEI (Polyetherimide). Lever seal in elastomer as per table. Medium temperature from -10°C to +100°C . Viscosity max 5 E° (~37 cStokes or mm²/s). Opening time ~10ms. Closing time ~10ms.

COIL - Rated for continuous duty in DC (direct current). Coil in class "F" (+155°C) wound by class "H" wires (+180°C) vacuum impregnated by polyester resin and encapsulated into glass fibre reinforced PBT (polybutylene-terephthalate).

Ambient temperature from -10°C to +60°C.

Standard voltages 12-24 V DC.

Voltage tolerance +10% -5% DC.

Electric plug connection (DIN 46340) or for 3 poles connector.

Protection degree IP65 as per EN 60529 if the coil is duly fitted with its plug connector.

Port size	Orifice size (mm)	Max pressure (bar)				Kv (m³/h)	Series and type		Power absorption			Seals	Notes	Weight (kg)		
		Gases		Liquids			Valve	Coil	AC (VA)		DC (W)					
		AC	DC	AC	DC				Inrush	Holding						
-	1,5	-	2	-	2	0,03	D350D01G	Z030A	-	-	4	EPDM	-	0,055		
						D350S01G										VMQ
						D350V01G										FPM

NOTES - Seal: EPDM = Ethylene-propylene elastomer VMQ = Silicone elastomer FPM = Fluoro-carbon elastomer
- No changes in table performances in case of assembling of adaptor base with M5 female threaded ports (G2998901) or slip-on ports (G2999101).
- Other voltages and frequencies on request

0105/0106

SPARE PARTS

Series D350-01G

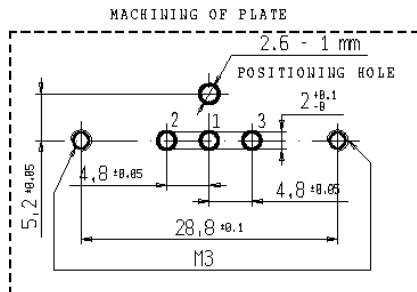
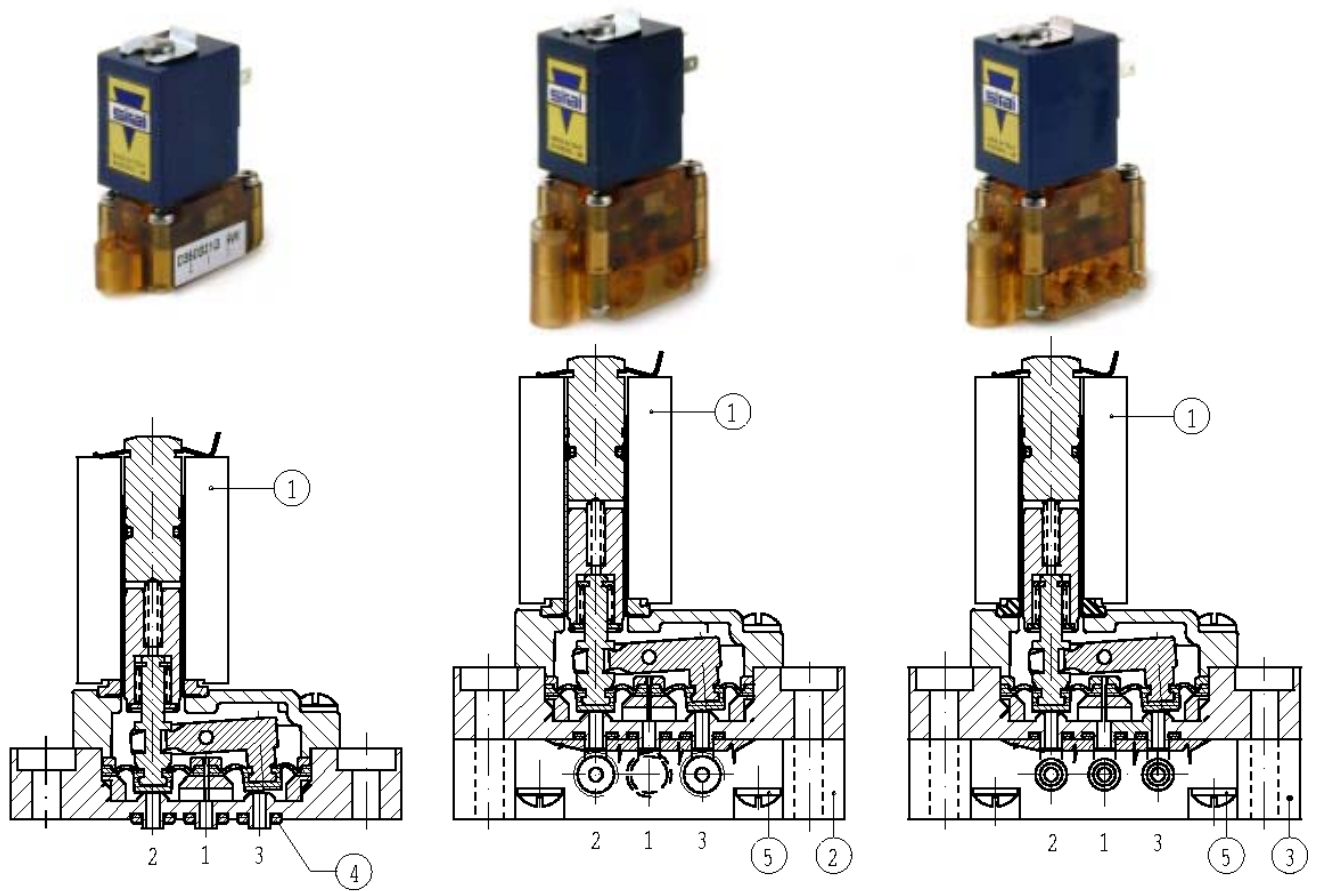

Kit Description

Interface plate with M5 ports

Interface plate with slip-on ports

O rings kit in EPDM for interface plate D350D01G

O rings kit in VMQ for interface plate D350S01G

O rings kit in FPM for interface plate D350V01G

Coil Z030A

Kit P.N.

G2998901

G2999101

GU2435000143

GU2427000143

GU2424000143

Consisting of:

Interface plate pos. 2
N° 4 fixing screws pos. 5

Interface plate pos. 3
N° 4 fixing screws pos. 5

N° 10 O-ring pos. 4

N° 10 O-ring pos. 4

N° 10 O rings pos. 4

Coil pos. 1

NB - THE VALIDITY OF REPORTED DATA IS REFERRED TO THE DATE OF ISSUE. POSSIBLE UPDATING ARE AVAILABLE ON REQUEST